

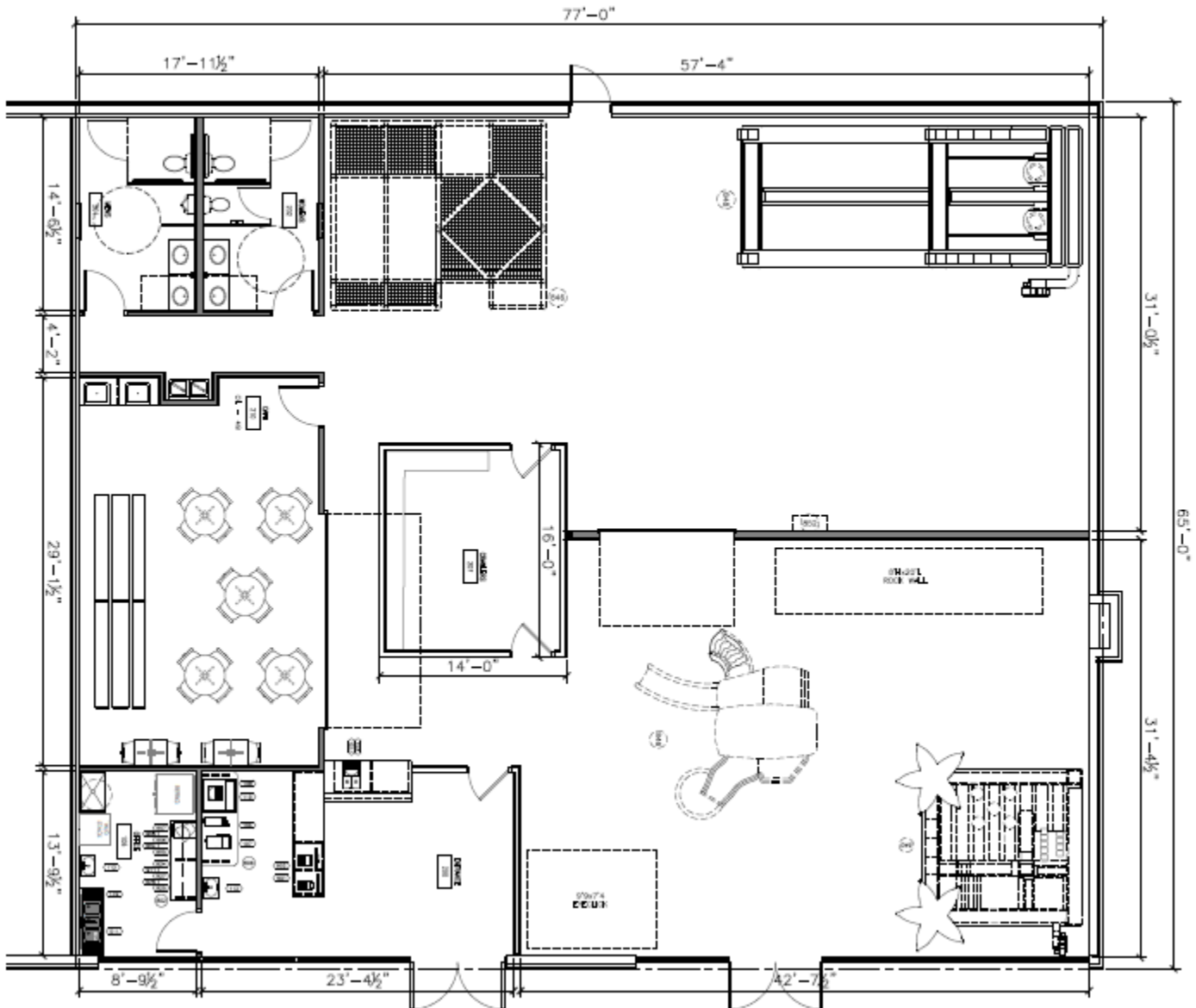

Monkey Bizness Design Specifications

Total Square Footage Target: 5,000 – 5,750 square feet

Concept Drawing:



Overall:

- Ceiling
 - Open ceiling in all areas except bathroom. Painting should include all ductwork, diffusers, electrical, camera data, and fire wiring and any other paintable surfaces.
 - Paint Color: Sherwin Williams Night Owl 7061

- Bathroom
 - Walls should extend up to ceiling
 - Hard lid/drywall painted P1, 10'-0" A.F.F.
- Music System
 - Installation of speakers and wire. Five speakers to be installed; two in each playroom and one in party room/cafe.
 - System will be powered from receiver at front desk area.
- Emergency/Egress Fixtures
 - Exit Signage as required by code
 - Astralite EEU2GW or similar
 - White Combo Exit Sign/Emergency Lights
 - Astralite TPUGWEM or similar
 - Exit Sign – Green or Red Letters
 - Emergency Lights as required by code
 - MaxiLume ELM-807BZ or similar
 - LED Emergency Light – Bronze
- Signage
 - All signed will be owner-supplied
 - Exterior signage to be custom fabricated by owner based on facility
- Millwork
 - All half-walls require a top cap. All top cap pieces must be free of any sharp edges. The contractor must round all corners and round top and bottom edges.
- Electrical
 - A 220 circuit may be required during buildout for optional washer/dryer
 - Thermostats outside of front counter should have covers installed on them.
 - All playroom, hall, crawler area, and café lighting should be run to one area behind front counter.
 - Attempt to run all wiring/stereo/data cables through ceiling prior to painting
 - Panic hardware installed on any exterior doors with restricted views from front counter.

Entry: 224+ sq. ft.

- Dimensions
 - 16' x 14' recommended minimum
- Walls
 - Wall separating entry from toddler and play areas should be 40" tall
 - 5/8" Gyp. Board standard
 - Drywall level 4 finish or greater – Hamilton prep coat recommended

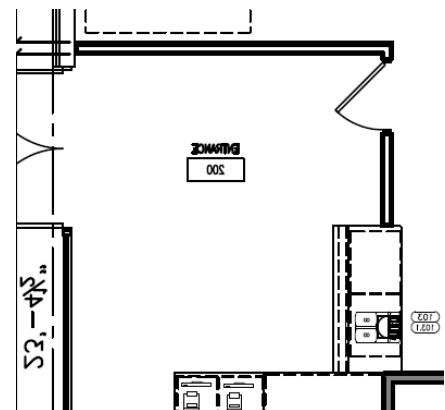

- Paint
 - Painting of the interior of the walls should be done based on selection of color from paint pallet below. All walls within the entry should be painted the same color.
 - All paints to be semi-gloss
- Flooring
 - LVT
 - Franchise owner chooses between selection below
 - 4" vinyl plank
- Electrical
 - (1) duplex outlet on wall opposite counter.
 - (1) duplex outlet to be installed for display cooler (120v only required)
- Doors
 - Entry
 - Double entry door, as provided by landlord
 - Playroom Entry
 - Solid core, stain-grade wood (birch preferred), selected stain finish with clear polyurethane
 - Match wall height
- Millwork
 - Serving counter standard counter top height.
 - Granite countertop – franchisee's specification
 - Minimum 30" base cabinet with storage below
 - Stain-grade wood, selected stain finish with clear polyurethane

(2) ADA Bathroom compliant bathrooms: 131 sq. ft. each

- Dimensions
 - 9' x 14'6" recommended minimum per bathroom
- Walls
 - 5/8" Green board
 - Sound batt insulation installed in walls
 - Walls should extend to ceiling
 - Drywall level 4 finish or higher
 - 3 Walls should be P1
 - 1 Wall should be painted accent (franchisee choice from color pallet below)
- Lighting
 - Lighting fixture above mirror
- Floor/Tile
 - Franchisor chooses between porcelain tile options from pallet below.

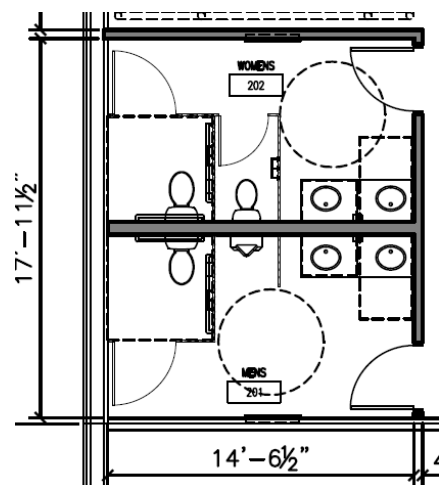

- Manufacturer: Stile²
 - Series: Segment
 - Dark: Mocha
 - Light: Ice
 - With either selection, grout shall be a coordinating color. All tile should be grouted and sealed.
 - Tiles size
 - Floor – 12” x 12”
 - Bullnose – 3”x12”
- Installed on floor and walls up to 27”
- Doors
 - 3’x7’x1-3/4” minimum, solid core, stain-grade wood (birch preferred), natural finish w/ clear
 - polyurethane
 - Knockdown hollow metal frame factory black – same spec as lobby door
 - Privacy leverset in brushed nickel
 - Auto return fixtures on all bathroom doors
- Fixtures
 - All fixtures must be ADA-compliant, installed per code
 - Water closet per spec (pg. 18) American Standard Cadet Flowise 2467.100 or equal, in white
 - Lavatory per spec (pg. 19 – 20) American Standard Lucerne model 0355.012 or equal, in white
 - upgrade ok with support center approval, GC to provide allowance
 - Mirror per spec (pg. 19) Bobrick Model B-165-2436 or equal, stainless steel satin finish
 - upgrade ok with support center approval, GC to provide allowance
 - Owner-provided lighting fixture above mirror OK
 - Grab bars per code
 - Toilet paper and paper towel dispensers per code, upgrades supplied by franchise owner
 - Koala changing station to be installed on wall opposite toilet
 - Standard 30’ white wall cabinet to be centered and installed 28” above toilet

Crawler Area – 224+ sq. ft.

- Dimensions
 - 16’ x 14’ recommended minimum
- Walls
 - Toddler area surrounded by walls on all four sides 40” AFF or to the top of cap
 - 5/8” Gyp. Board standard
 - Drywall level 4 finish or greater – Hamilton prep coat recommended

- Walls must be covered in broadloom carpet to 40" A.F.F. or to the underside of the top cap at partial height walls.
 - Broadloom carpet to match flooring below
- Flooring
 - 12' x 12' custom printed carpet to be installed on 1" carpet pad centered in crawler area
 - Franchisee has choice between broadloom carpet to fill out remainder of crawler area, benches, and walls. Franchisee to choose one of the following:
 - Manufacturer: Mannington Commercial
 - Series: Everywear III
 - Raffia 4418
 - Olive Wood 5401
- Benches
 - Benches are framed into the half walls as indicated above in the crawler area
 - 18" high and 18" deep
 - Seat will have layer of 1" carpet padding
 - Covered by broadloom carpet, same as wall covering
- Doors
 - Two (2) Solid core, stain-grade wood (birch preferred), selected stain finish with clear polyurethane.
 - Match wall height

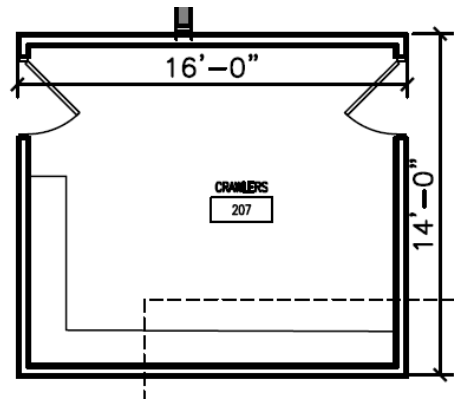

Front Counter Area 176+ sq. ft.

- Dimensions
 - 16' x 11' recommended minimum
- Wall
 - All finishes and colors consistent with play room/café/hall finishes
- Flooring
 - LVT
 - Consistent with entry and front desk floor selection
 - Transition piece should be laid between hall and play floor
 - 4" rubber base in either Roppe Brown(110) or Black (100) to be used as selected by Franchisee
- Millwork: Front Desk
 - Contact Gabe Boucher, Worlds of Wow, at 940-765-4708
- Power / Data
 - White receptacles, switches, plate covers, etc.

- (2) quad outlets to be installed for POS stations under counter
- (3) duplex outlets to be installed above counter on back wall. One such outlet should be installed to the left of sink.
- (1) duplex outlet to be installed for undermount fridge on back wall.
- (1) duplex outlet to be installed for display cooler (120v only required)
- Plumbing
 - (2) waterlines required for Soda and Coffee machines.
 - Coffee Machine: Plumbed 3/4" STD hose connection with separate valve shutoff
 - Soda Machine: Plumbed 1/2" supply line with separate shut-off valve. Installed directly next to sink.
 - CO2 must be located on a solid surface chained in place. If CO2 is under cabinet, a minimum of 30" under counter clearance is needed.

Storage Room (Behind Front Counter) 176+ sq. ft.

- Dimensions
 - 16' x 11' recommended minimum
- Wall
 - All finishes and colors consistent with play room/café/hall finishes
- Flooring
 - LVT
 - Consistent with entry and front desk floor selection
 - Transition piece should be laid between hall and play floor
 - 4" rubber base in either Roppe Brown(110) or Black (100) to be used as selected by Franchisee
- Plumbing
 - Three compartment sink installation (pg. 24)
 - Plumbing line adequate for stack washer/dryer
- Power / Data
 - 120/240V for Stack Washer/Dryer
 - (1) quad outlet to be installed on wall opposite sink

Utility Room/Storage Closet (if required/requested)

- Build and furnish per code
- Walls
 - 5/8" Gyp. board standard
 - Painted P1
 - Wall mounted wire shelving – 18" depth minimum, sized to fit
- Ceiling
 - Standard white 2'x2' suspended ceiling tile and grid (see spec – pg. 27)

- Doors
 - 3'x7'x1-3/4" minimum, solid core, stain-grade wood (birch preferred), natural finish w/ clear polyurethane
 - Knockdown hollow metal frame factory black
 - Passage or locking leverset in brushed nickel
- Lighting
 - 2'x2' troffers or 6" recessed cans and lighting on dedicated switch (see spec – pg. 28)
- Plumbing/Mechanical
 - Mop sink and drain (per code)
 - Hot water heater (raised above ceiling ok); minimum 10-gallon
 - Washer hot/cold connection (optional – owner's choice)
 - Dryer vent to building exterior; wall penetration with landlord approval OK or use existing (options – owner's choice)

Café and Hall Area

The remainder of the facility not described above is classified as the café, hall, and play floor. Because these items are an “open” concept, there are elements that will be discussed as it pertains to all three areas. The items in this section pertain only to the Café and Hall area, as shown in the graphic in this section.

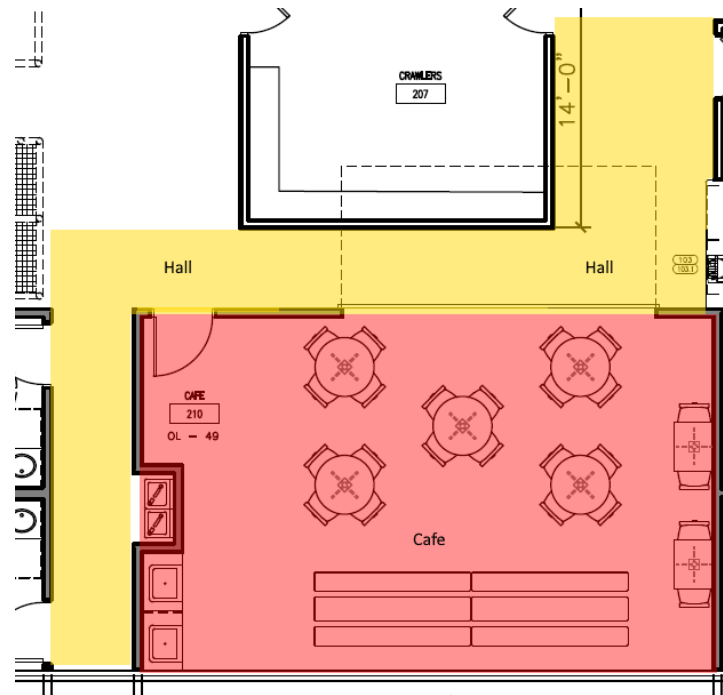

- Walls
 - 5/8” Green board
 - Sound batt insulation installed in walls
 - Walls should extend to ceiling
 - Drywall level 4 finish or higher
 - 3 Walls should be P1
 - 1 Wall should be painted accent (franchisee choice from color pallet below)
 - Approximate 16’ opening for interior garage door.
- Flooring - Hallway
 - LVT from selected styles below
 - Consistent with entry and front desk floor selection
 - Transition piece should be laid between hall and play floor
 - 4” rubber base in either Roppe Brown(110) or Black (100) to be used as selected by Franchisee
- Flooring – Café/Party Room
 - VCT
 - Transition piece should be laid between café/party room and hallway
 - 4” rubber base in either Roppe Brown(110) or Black (100) to be used as selected by Franchisee
 - There will be VCT wallcovering to 24” A.F.F. at all walls
 - Tiles will be arranged in a specific pattern in such a way that no color is the same vertically or horizontally. Washed linen is required to be used in any pattern. The owner must choose 3 colors (including Washed Linen).
 - All tiles are part of Armstrong’s Standard Excelon Imperial Texture line.
- Lighting (Franchisee picks between options)
 - LED High Bay Fixture must be used throughout remainder of facility
 - OR -
 - Commercial Globe String Lights (pg. 26) to be hung over café area, approximately 10’ high
 - Electrical duplex outlet to be installed in corner of café and bathroom to accommodate lighting
 - Should be hung in a “zig-zag” pattern as detailed below:
 - Brown bamboo posts should be affixed to lights where brown circles appear in graphic above
- Sink Station
 - The room must have a high (33”) and low (24”) counter with white basin sinks and chrome faucets. There will be a garbage disposal in the high sink. The counter may be plastic laminate or solid surface depending on budget and franchisee preference.
 - A 4” backsplash is required along the wall.

- The lower cabinets will be plastic laminate and have double doors. Door hardware to be standard brushed stainless pulls.
- Drinking Fountains
 - Located outside of bathrooms
 - (2) Two Elkay ADA Barrier Free Water Cooler, Light Gray Granite, 2 Station 115V, 60 HZ, 5 Amps should be placed between the two restrooms. Plumbing and electrical should be coordinated as such.
 - Outlets for water fountains should be at levels that allow them to be covered by the fixtures.

Play Floor

- Flooring
 - TruGrass Tan Artificial Grass (pg. 14)
 - No padding installed underneath
 - 4" rubber base in either Roppe Brown(110) or Black (100) to be used as selected by Franchisee
- Lighting
 - LED High Bay Fixture must be used throughout remainder of facility

Play Floor, Café, Hall Areas

- Walls
 - 5/8" Gyp. board standard
 - Drywall level 4 finish or greater
 - East/West and North/South walls painted same colors. Selection made by franchisee from Color Palette
- Power
 - Per code – GFCI outlets as requested
 - White receptacles, switches, plate covers, etc.
 - No outlets in crawler area
 - Duplex outlets minimum 12 feet apart along all play floor walls

Rock Wall Construction

- The horizontal rock wall is custom built and should be approximately 8 feet high with a minimum width of 20 feet.
- It is up to you to determine that the stud wall is of sound structural condition.
- Installation and Materials
 - 4' x 4' x 3/4" sheets of plywood to be installed in a gird measuring 8' x 20'
 - 2" x 4" x 96" & 2" x 6" x 96" used as braces. Installation wall should be level.
 - 3/8" x 5" Lag Screws
 - 1-3/4" Screws

- Flat Washers
- Sub Wall Preparation
 - Lay out all of the 2" x 4" and 2" x 6" boards on a level surface.
 - Using the 1-1/4" spade drill bit, drill out (3) 1/2" deep countersunk holes as shown in.
 - Repeat step 2 with 5 holes for 2" x 6'
 - Using the 5/16" auger drill bit, drill out the center of every countersunk hole you created in the previous step
- Sub Panel Wall Construction
 - Working from left to right, you will construct the sub wall.
 - Start by taking a 2" x 4" and lining it up with the stud on the farthest left. Level the 2" x 4" and proceed to drill a 5" deep hole through the center hole of the 2" x 4" and into the stud behind the drywall with your 5/16" drill bit.
 - Using your drill with a 3/8" socket attached, take a 3/8" lag bolt and drill it into the hole until snug. Repeat this process on the #2, #3, #5, #6, #8, #9 and #10 studs. Note layout pattern.
 - On the #4, #7 #11, and #14 studs, repeat the previous steps using the (2) 2" x 6" boards, using the additional counter sunk holes for additional Lag Bolts.

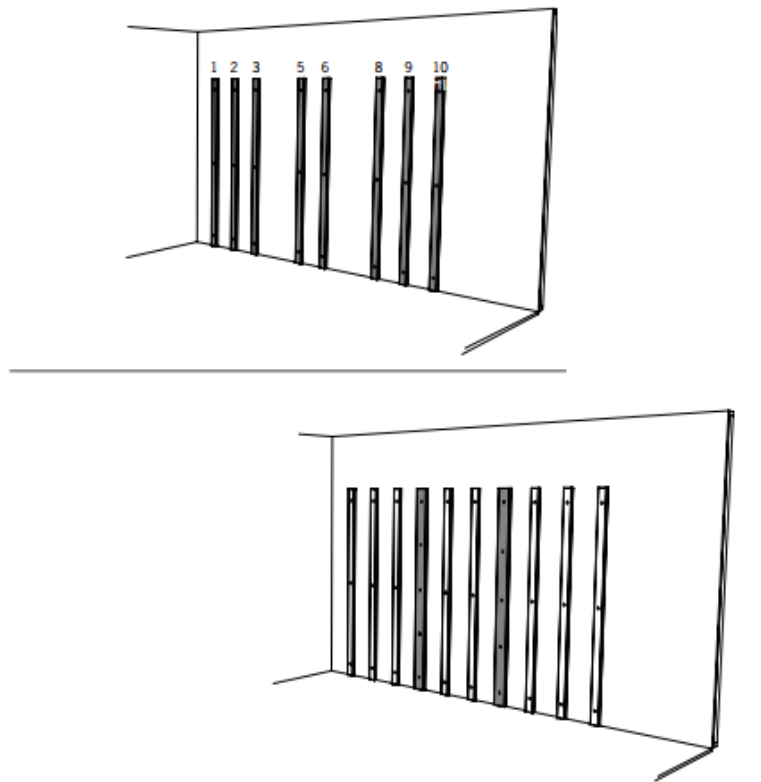

- Installation of Climbing Panels
 - Working from bottom to top, left to right, you will now install the panels for your climbing wall. Align the left side of a panel with the left side of the left most 2" x 4".
 - Level the Panel. Sink (1) #8 1-3/4" screws through the panel into the 2" x 4" using your drill with the Phillips head drill bit.
 - Secure the panel to the (4) sub wall boards using (1) #8 screw every 12"
 - Repeat the previous steps for the remaining panels.
- Finishing
 - Custom Monkey Bizness Wallpaper to be installed over completed panels
 - Rock Wall holds to be installed per instructions (read instructions prior to installation of panels).
 - Check hand holds for looseness and tighten. Do not overtighten!

Color Pallet

Paint

Monkey Bizness owners are given the opportunity to paint their cafes, bathrooms, and play areas according to their preference. Monkey Bizness uses Sherman Williams Duralast Line paint exclusively. The colors each owner selects must be from the template provided below. No adjoining walls shall be painted the same color. In the bathrooms, you may select one color to be used throughout the room.

Morning Sun
6672

Portabello
6102

Marigold
6664

Decisive
Yellow
6902

Overt Green
6718



Ceiling Paint

Night Owl
7061



Stain

Sherman Williams Wood Classics Interior Oil Stain

Weathered Teak
3134

Bright Cherry
3109



Flooring – LVT

Shaw Insight Plank – Style No. SA377

Blazing Skies
00698



Earhart Brown
00634



Flooring – VCT

All tiles are part of Armstrong's Standard Excelon Imperial Texture line.

Washed Linen
51810



Humus
51869



Lemon Yellow
51812



Little Green Apple
51866



Marina Blue
51820



Flooring – Porcelain Tile

Color Option 1
Stile²
Segment
Mocha



Color Option 2
Stile²
Segment
Ice



Rubber Base

Roppe 700 Series

Black
100



Brown
110



Crawler Area Surround Carpet

Mannington Commercial Everywear III

Olive Wood
5401



Raffia
4418



Turf Evolutions TruGrass Tan



Exit Sign/Emergency Light Combo

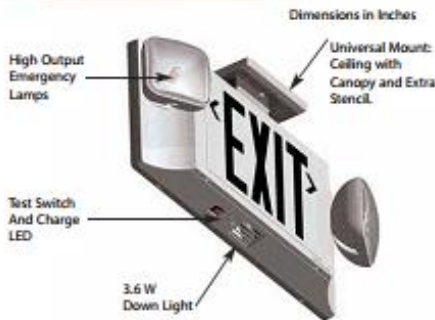

TYPE _____

CATALOG# _____

EEU-2-LED

L.E.D. EXIT / EMERGENCY LIGHT COMBINATION UNIT

GENERAL DESCRIPTION

The unit, featuring sleek shallow height (8.5"), will blend nicely into any environment. The EEU-2 offers a smooth contoured transition from the exit to the two emergency heads while providing the flexibility of back, or canopy mount with an additional exit stencil standard. A downlight feature adds to the value which operates only in emergency mode illuminating the doorway is standard. Unit is also remote capable. (See EEU-2-16)

HOUSING

UV Stable Thermoplastic flame retardant meets UL standard 95-VA. Standard white or black finish (matches all products in same family) features quick and easy installation via a snap-in design. Unit installs in less than 5 minutes and is prewired at factory. Replaceable chevron directional indicator offers a choice of direction on both stencils.

ILLUMINATION

Two L.E.D. lamps mounted in precision formed photometrically optimized reflector assemblies exceed illumination required by UL 924. The soft etched lens eliminates glare and striation often associated with prismatic spread lenses while providing even distribution along areas of egress. Long lasting high output AllnGaP LED's with the highest performance and least degradation available in the market with a rated life of 25 years plus illuminates the exit face.

ELECTRONICS AND BATTERY

Dual Voltage 120/277 VAC input facilitates the fully automatic Solid State charging system which features (LVD) Low Voltage Disconnect, AC lockout installation, brown-out protection, AC indicator LED light with push to test button standard. The maintenance-free NiCd battery provides a minimum of 90 minutes of illumination in emergency mode with an average life of 12 years. Operating Temperature Range: 0°-40°C

CODE COMPLIANCE

Tested and Listed to UL 924 for damp location, meets or exceeds NFPA, NEC, and OSHA illumination standard.

WARRANTY

5 years on housing and electronics with a 5 year pro rated warranty on battery.

COMMERCIAL SERIES

EEU-2-LED

MODEL

LETTER COLOR

HOUSING COLOR

FACTORY INSTALLED OPTIONS

R • RED
G • GREEN

B • BLACK
W • WHITE

220 • 220 VAC INPUT
SD • SELF DIAGNOSTICS
SW • SPECIAL WORDING



20 POCONO ROAD • BROOKFIELD • CONNECTICUT • 06804 • 203.775.0172 (P) • 203.775.0797 (F)
CO-10

LED Exit Sign



DIMENSIONS

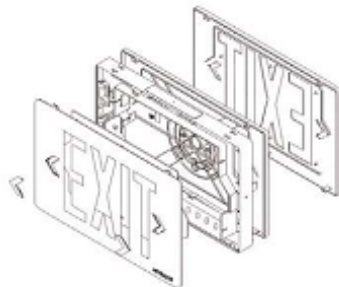
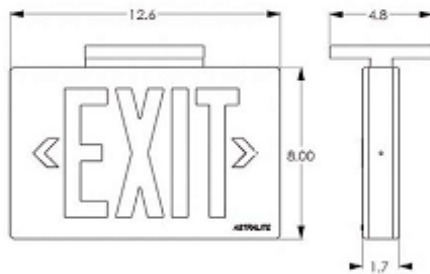

TYPE _____

CATALOG# _____

COMMERCIAL SERIES

TP-U

UNIVERSAL THERMOPLASTIC EXIT SIGN

GENERAL DESCRIPTION

The light style thermoplastic LED exit sign provides a sleek, low-profile compact design, packaging the highest level of quality and even illumination with the easiest and quickest installation available in the market today.

HOUSING & FACE DESIGN

The housing is UV stable injection-molded thermoplastic listed to UL 95-VA standard. Stencils are made of the same material with field selectable universal snap in and out chevrons.

ILLUMINATION

Long lasting high output AlInGaP LEDs with minimum degradation over life of LEDs. Unit draws less than 2.5 watts and meets all Energy Star Requirements. Available in red or green.

ELECTRONICS

Input is dual volt standard 120/277 60Hz. Unit is damp location listed 50°-104°F (10°-40°C). EM option features solid state design with low voltage disconnect, AC lock-out, brown-out protection, and AC indicator LED with test switch. Battery is standard Nickel Cadmium.

CODE COMPLIANCE

Tested and Listed to UL 924 for damp location, meets or exceeds NFPA, NEC, and OSHA illumination standard.

WARRANTY

5 years on housing and electronics with a 7-year pro-rated warranty on the battery.

TP SERIES	U MOUNTING	LETTER COLOR	HOUSING COLOR	UNIT POWER CONFIGURATION	FACTORY INSTALLED OPTIONS
U • UNIVERSAL	R • RED G • GREEN	W • WHITE B • BLACK GL • GOLD METALLIZED SL • SILVER METALLIZED R • RED G • GREEN BLU • BLUE Y • YELLOW	AC • AC ONLY EM • BATTERY BACKUP DI • TWO TRANSFORMER INPUT DC • REMOTE DC INPUT (6 TO 24 VDC)	FL • FLASHER ONLY. FLASHES ONLY WHEN UNIT GOES INTO EMERGENCY CONDITION. BATTERY UNITS ONLY. FA • FIRE ALARM INTERLOCK. FLASHES IN BOTH DIRECTIONS WHEN SIGNAL FROM FIRE ALARM PANEL IS RECEIVED (6 TO 24 VDC). FLA • FL OPTION WITH AUDIBLE ALARM. BATTERY UNITS ONLY. FAA • FA OPTION WITH AUDIBLE ALARM. SW • SPECIAL WORDING. REARABLE. SD • SELF DIAGNOSTICS	



LED Emergency Light

ELM-807

Outdoor Die-Cast Emergency Light with Battery Back-Up

Architectural

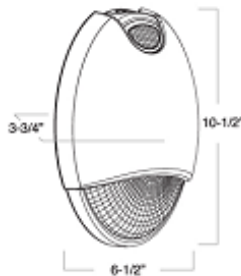

Catalog Number: ELM-807-WH	
Project Name:	Type:
Note:	
MAXILUME ARCHITECTURAL LIGHTING	

FEATURES

This fixture is an excellent choice when an attractive emergency light is required. In cases of AC power loss, it provides a minimum of 120 minutes illumination. A trouble-free lead-calcium battery is provided with the fixture.

HOUSING

- UL 94V-0 flame rating
- Architectural, low-profile design
- Die-cast aluminum housing
- Polycarbonate lens and mirror reflector
- Suitable for wet location

MOUNTING

- Wall or ceiling mounting.

ELECTRICAL

- 120V or 277V VAC Dual voltage operation
- Test switch and charge rate indicator

LAMPS

- 2 X 6V 6W Xenon lamps for emergency mode.

BATTERY

- Sealed-lead acid battery (6V 5A) delivers more than 90 minutes capacity to emergency lamps.
- 24 hours recharge after 90 mins. discharge.
- Low voltage battery disconnection-preventing deep discharge damage to the battery.

TESTING

- Test Button
- Solid state line latched low voltage disconnect to avoid deep discharge
- Safeguarded against short circuits
- Power is automatically interrupted in cases of brown-out

LISTED

- Damp location approved
- ETL

ELM-807 • ITEM SELECTOR: (Please check the boxes below for the option desired)

HOUSING COLOR	
<input checked="" type="checkbox"/>	WH • White
<input type="checkbox"/>	BZ • Bronze
<input type="checkbox"/>	SN • Satin Nickel

Specified:

ELM-807 WH
HOUSING COLOR



MAXILUME ARCHITECTURAL LIGHTING
A division of
Elite Lighting

Submital form is available @ www.maxilume.com
Tel: 323-888-1973 • Fax: 323-888-1977

Specifications and Dimensions
subject to change without notice.
REV: MAXILUME-SPEC-03-10-2011

American Standard

Style That Works Better

BARRIER FREE

CADET FloWise™ RIGHT HEIGHT™ ELONGATED PRESSURE-ASSISTED TOILET 1.1 gpf / 4.2 Lpf
VITREOUS CHINA

CADET FloWise™ RIGHT HEIGHT™ ELONGATED PRESSURE-ASSISTED TOILET 1.1 gpf / 4.2 Lpf

- 2467.100**
 - Vitreous china
 - High Efficiency, Ultra Low-consumption (1.1 gpf/4.2 Lpf)
 - EverClean® surface inhibits the growth of stain and odor-causing bacteria, mold, and mildew on the surface
 - Meets EPA WaterSense® criteria
 - Bowl rim at 16-1/2" for accessible applications
 - Elongated bowl
 - Pressure-assisted siphon jet flush action
 - Fully-glazed 2-1/8" trapway
 - 10 x 12" water surface area
 - Close-coupled Flushometer tank*
 - Metal chrome trip lever
 - Speed Connect® tank/bowl coupling system
 - Sanitary dam on bowl
 - Two bolt caps
 - 100% factory flush tested
 - 12" Rough-in



- 2467.136** Same as above except with slotted rim bowl for bed pan holding (White only)
- 3483.100** Bowl with two bolt caps
- 3483.001** Same as above, Universal Bowl
- 3484.001** Bowl with slotted rim for bed pan holding with two bolt caps (White only)
- 4142.100** Tank complete with coupling components

Nominal Dimensions:
768 x 521 x 781mm (30-1/4" x 20-1/2" x 30-3/4")

Fixture only, seat and supply by others
Recommended working pressure range
25 psi - 80 psi

Alternate Configurations Available:

- 4142.601** Tank and tank cover only with tank cover locking device
- 4142.801** Tank and tank cover only with right hand trip lever
- 4142.901** Tank complete with right hand trip lever and tank cover locking device

Compliance Certifications - Meets or Exceeds the Following Specifications:

- ASME A112.19.2-2008 / CSA B45.1-08 for Vitreous China Fixtures
- US EPA WaterSense® Specification for HET's

To Be Specified:

- Color: White Bone Linen Black
- Seat: American Standard #5324.019 "Rise and Shine" (with easy to clean lift-off hinge system) solid plastic closed front seat with cover.
- American Standard #5321.110 EverClean® seat with Slow Close snap-off hinges.
- Alternate Seat:
- Supply with Stop:

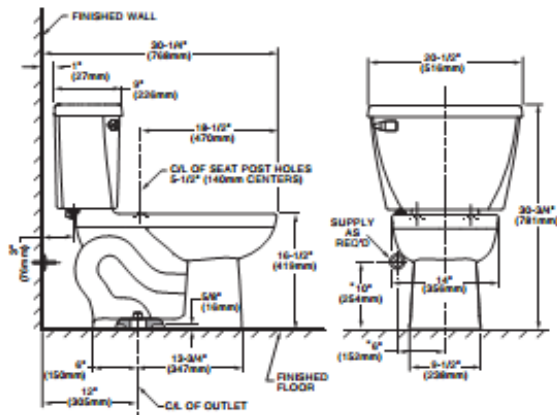

NOTES:
THIS TOILET IS DESIGNED TO ROUGH-IN AT A MINIMUM DIMENSION OF 305mm (12") FROM FINISHED WALL TO C/L OF OUTLET. SUPPLY NOT INCLUDED WITH FIXTURE AND MUST BE ORDERED SEPARATELY.
* DIMENSION SHOWN FOR LOCATION OF SUPPLY IS SUGGESTED.

IMPORTANT: Dimensions of fixtures are nominal and may vary within the range of tolerances established by ASME A112.19.2-2008 / CSH B45.1-08. These measurements are subject to change or cancellation. No responsibility is assumed for use of superseded or voided pages.



MEETS THE AMERICANS WITH DISABILITIES ACT GUIDELINES AND ANSI A117.1 REQUIREMENTS FOR ACCESSIBLE AND USABLE BUILDING FACILITIES - CHECK LOCAL CODES.

Wall-Hung Lavatory

*American
Standard*

LUCERNE™
WALL-HUNG LAVATORY
VITREOUS CHINA

 BARRIER FREE

LUCERNE™ WALL-HUNG LAVATORY

- Wall-hung sink
- Vitreous china
- Front overflow
- D-shaped bowl
- Self-draining deck area with contoured back and side splash shields
- Faucet ledge
- Compliant with Texas accessibility standard (TAS) for children age group 13 and up

Faucet holes on 203mm (8") centers (Illus.):

- 0356.028** For exposed bracket support
Shown with 4801.862 Amarilis Heritage faucet with Triune Cross handles (not included)
- 0356.015** For wall hanger (included) or concealed arms support
- 0356.915** For wall hanger (included) or concealed arms support
 - Less overflow

Faucet holes on 102mm (4") centers:

- 0355.027** For exposed bracket support
- 0355.012** For wall hanger (included) or concealed arms support
- 0355.912** For wall hanger (included) or concealed arms support
 - Less overflow

Single center faucet hole (Illus.):

- 0356.041** For exposed bracket support
Shown with 1340.000 metering faucet (not included)
- 0356.421** For wall hanger (included) or concealed arms support
- 0356.921** For wall hanger (included) or concealed arms support
 - Less overflow
- 0356.439** For wall hanger (included) or concealed arms support
 - Single faucet hole on right
- 0356.066** For exposed bracket support
 - Single faucet hole on right

Nominal Dimensions:

521 x 464mm
(20-1/2" x 18-1/4")

Bowl sizes:

381mm (15") wide
254mm (10") front to back
165mm (6-1/2") deep

Compliance Certifications -

- Meets or Exceeds the Following Specifications:**
- ASME A112.19.2 / CSA B45.1 for Vitreous China Fixtures



0356.028



0356.041

SEE FOLLOWING PAGES FOR ROUGHING-IN DIMENSIONS

To Be Specified:

- Color: White
- Faucet*:
- Faucet Finish:
- Supplies:
- 1-1/4" Trap:
- Nipple:
- Bracket Support (by others):
- Concealed Arms Support (by others):

* See faucet section for additional models available



MEETS THE AMERICANS WITH DISABILITIES ACT GUIDE-
LINES AND ANSI A117.1 ACCESSIBLE AND USABLE
BUILDINGS AND FACILITIES - CHECK LOCAL CODES.
Top of front rim mounted 864mm (34") from finished floor.

M37

© 2016 AS America Inc.
spec_0355-0356 Lucerne WallHung Lavs Rev. A 8/16



- 0356.028 8" CTRS FOR EXPOSED BRACKET SUPPORT
- 0356.015 8" CTRS FOR WALL HANGER OR CONCEALED ARMS
- 0356.915 LESS OVERFLOW

- 0355.027 4" CTRS FOR EXPOSED BRACKET SUPPORT
- 0355.012 4" CTRS FOR WALL HANGER OR CONCEALED ARMS
- 0355.912 LESS OVERFLOW

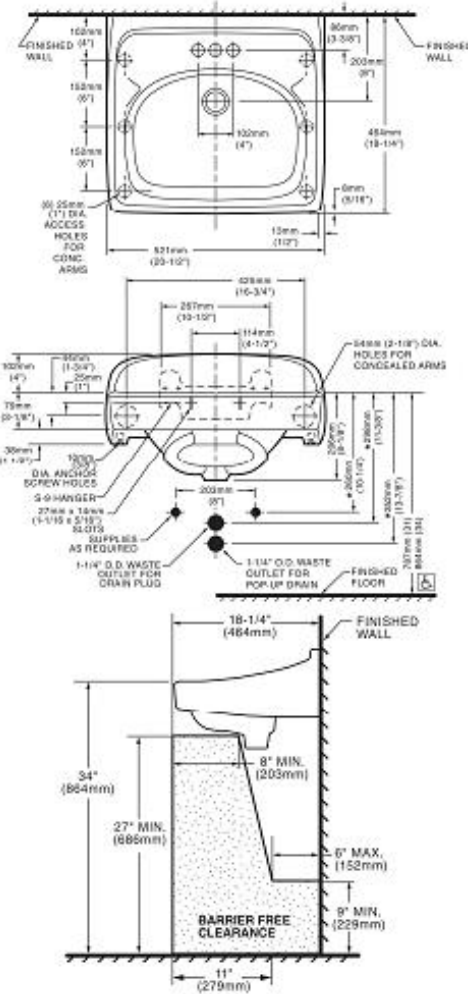
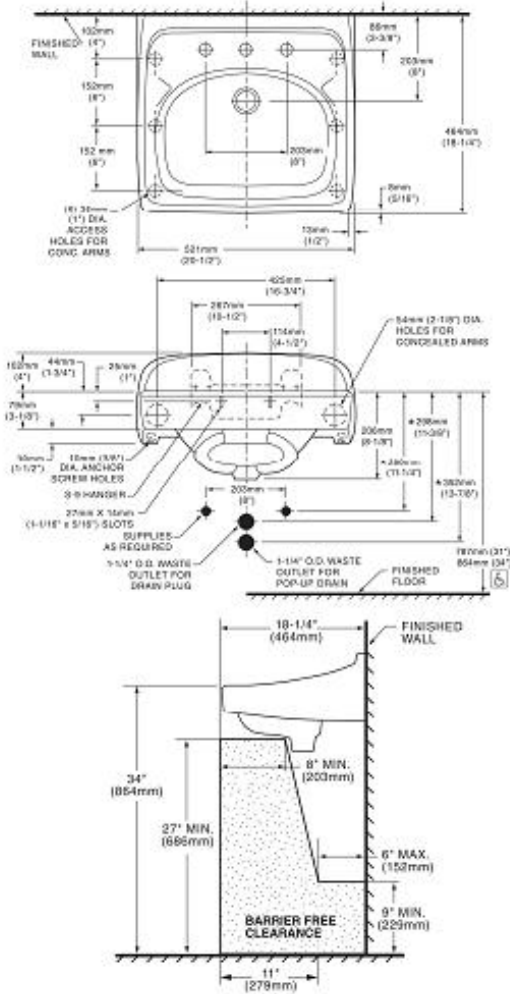

NOTES:
 * DIMENSIONS SHOWN FOR LOCATION OF SUPPLIES AND "P" TRAP ARE SUGGESTED.
 PROVIDE SUITABLE REINFORCEMENT FOR ALL WALL SUPPORTS.
 FITTINGS NOT INCLUDED AND MUST BE ORDERED SEPARATELY.
 CONCEALED ARM SUPPORT AS REQUIRED TO BE FURNISHED BY OTHERS.

IMPORTANT: Dimensions of fixtures are nominal and may vary within the range of tolerances established by ANSI Standard A112.19.2. These measurements are subject to change or cancellation. No responsibility is assumed for use of superseded or voided pages.

LAVATORY DESIGNED TO MEET ADA HANDICAPPED GUIDELINES WITH MOUNTING HEIGHT SET AT 864MM (34") ABOVE FINISHED FLOOR.



Designer's Notes:

1. Special-order sizes available on request.
2. Maximum size mirror available, 96" x 72" (244 x 183cm); minimum size, 12" x 12" (30 x 30cm).
3. All Bobrick framed mirrors are manufactured to overall width and height dimensions. EXAMPLE: A 24" x 36" (61 x 91cm) mirror will be furnished 24" x 36" (61 x 91cm) outside-of-frame to outside-of-frame.
4. To specify special sizes use Series Number followed by width x height in inches. EXAMPLE: B-165 2024 20" x 24" (51 x 61cm)
5. Bobrick framed mirrors are manufactured to a tolerance 1/8" (3.2mm).
6. For sufficient space to lift mirror onto wall hanger(s), provide 1" (25mm) minimum clearance above top of mirror frame.
7. Provide 1" (25mm) minimum clearance at bottom of mirror for unlocking mirror from wall and 1/2" (12.7mm) minimum clearance on each side.

**Snap Locking Design
(Rear View)**

Figure 1

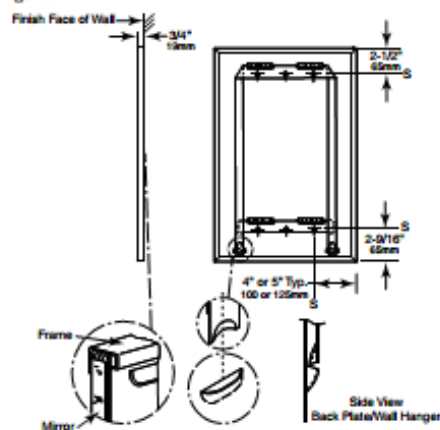

STANDARD B-165 SERIES MIRRORS

MODEL NO.	OVERALL SIZE	
	W	H
B-165 1824	18" (46cm)	24" (61cm)
B-165 1830	18" (46cm)	30" (76cm)
B-165 1836	18" (46cm)	36" (91cm)
B-165 2436	24" (61cm)	36" (91cm)
B-165 2448	24" (61cm)	48" (122cm)
B-165 2460	24" (61cm)	60" (152cm)

**Lock Tab Design
(Rear View)**

Figure 2

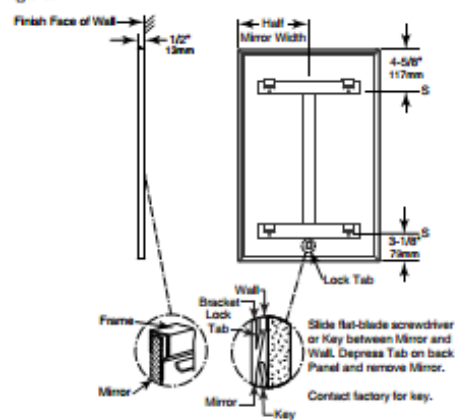

STANDARD B-165 SERIES MIRRORS

MODEL NO.	OVERALL SIZE	
	W	H
B-165 4836	48" (122cm)	36" (91cm)

All Other Size Mirrors

Note: Mirrors greater than 30" in width will have multiple hanger brackets with a typical 8" off each edge.

Width	Hanger Pockets
Up to 30" (76cm)	1
Over 30" up to 72" (76 to 183cm)	2
Over 72" up to 96" (183 to 274cm)	3

continued . . .

The illustrations and descriptions herein are applicable to production as of the date of this Technical Data Sheet. The manufacturer reserves the right to, and does from time to time, make changes and improvements in design and dimensions.

Rev. 05/25/17™ Printed in U.S.A.
© 2017 by Bobrick Washroom Equipment, Inc.

LVT

RESILIENT

INSIGHT
luxury vinyl plank

Handscraped Hickory



Limed Hickory

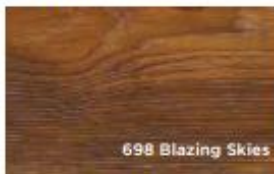

European Oak



shawfloors.com
08.16.2016



INSIGHT

RESILIENT

Style Number	SA377
Construction	VersaLock
Size	6" x 48"
Thickness	3.2mm
Wear Layer	6mil
Finish	OptiClean Urethane
Edge description	Square
SF per carton	27.58
SF per pallet	2,151.24
Installation	Floating
Classification	Good

Features

- Water resistant

Suggested Underlayment

Style Name	Style Number
Groundworks	074VS 100 SF per roll
Hush II	070VS 280 SF per roll

Coordinating Trim



*Packaged with molding track

Benefits



shawfloors.com
08.16.2016



Product Description

Roppe 700 Series Wall Base is a unique thermoplastic rubber (TPR) wall base product that is as attractive as it is affordable. 700 Series wall base is incredibly durable, allowing it to stand up to a wide range of use when compared to vinyl wall base.

700 Series wall base is designed for use in both commercial and residential wall base applications. 700 Series wall base is available in various heights, from 2 1/2" to 6", and in cove or no toe to match a variety of flooring installations and application requirements.

700 Series wall base is FloorScore certified, contributes to LEED credits and meets a variety of VOC requirements. 700 Series wall base is manufactured in the USA.

Features

- **Extremely Durable**
- **Extremely Flexible**
- **Will Not Shrink, Gap or Cup**
- **Recycleable** (*IMPACT Recycling Program*)
- **Qualifies for LEED® Credits**
- **FloorScore® Certified**

Technical Data

Toe Styles: **Cove, No Toe**

Nominal Base Height: **2 1/2" (63.5 mm)**
4" (101.6 mm)
4 1/2" (114.3 mm)
6" (152.1 mm)

Nominal Base Length: **48" Sections (1.22 m)**
120' Rolls (36.58 m)

Nominal Base Thickness: **1/8" (3.2 mm)**

LEED v2009 IEQ Credit 4.1: **Qualifies**

ASTM F1861 - Resilient Wall Base: **Type TP, Group 2, Style A & B**

ASTM E648 (NFPA 253) - Critical Radiant Flux: **Class I, > 0.45 W/cm²**

ASTM E662 (NFPA 258) - Smoke Density: **Passes, <450**

ASTM E84 - Flammability: **Class A**

CAN/ULC-S102.2 - Surface Burning: **FSR 10, SDS 60**

Acclimation Time: **48 Hours**

Storage & Acclimation Temperature: **65° - 85° F**

Additional Information

Approved Adhesives

AW-510 Acrylic Wet-Set Adhesive
WB-600 Acrylic Wall Base Adhesive
C-630 Contact Adhesive

Additional Accessories

Inside and outside factory corners, are available to match wall base installations.

Custom Offerings

Product color may be altered to match other colors in 12 carton increments with a minimum of 48 cartons.

Availability, Cost & Samples

Roppe Flooring products are sold through distribution. To locate the nearest distributor, visit roppe.com or send an e-mail to support@roppe.com.

Technical Documents & Support

Additional product resources and technical documents are available online at roppe.com. For additional technical support, send an e-mail to solutions@rhctechical.com.



OMSID # 205703188
Model # THD338399.1a

USE AND CARE GUIDE

Elite 2-Door Wall Cabinet - White

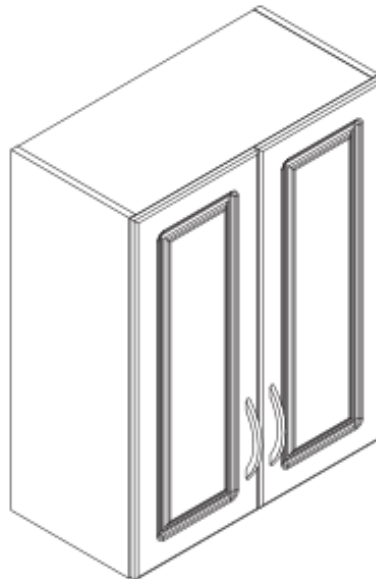

Questions, problems, missing parts? Before returning to the store,
call Hampton Bay Customer Service
8 a.m. - 6 p.m., EST, Monday - Friday

1-855-HD-HAMPTON

HAMPTONBAY.COM

THANK YOU

We appreciate the trust and confidence you have placed in Hampton Bay through the purchase of this bookcase. We strive to continually create quality products designed to enhance your home. Visit us online to see our full line of products available for your home improvement needs. Thank you for choosing Hampton Bay!

3-Compartment Sink

16GA.304S/S sink

3comp:10"X14"X12"

16GA.galvanized leg and socket, plastic bullet feet

No drainboard, Centered drain with 3.5" drain basket

Wooden skid packing

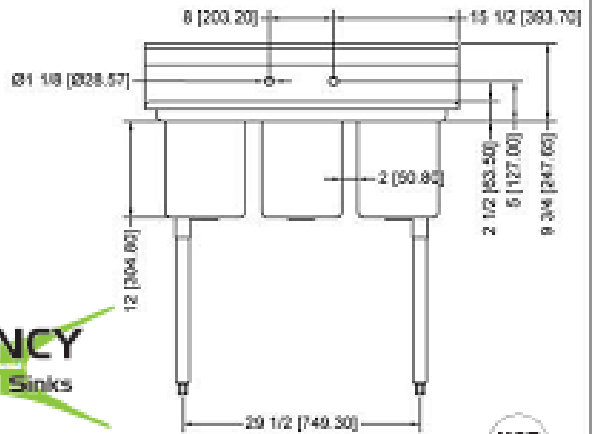
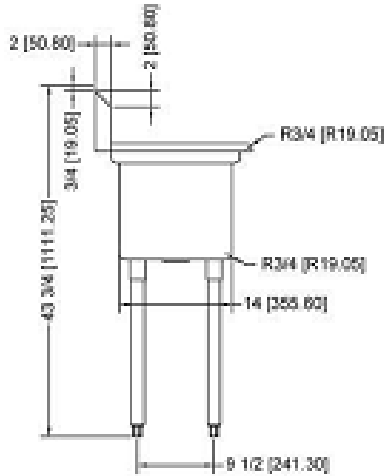
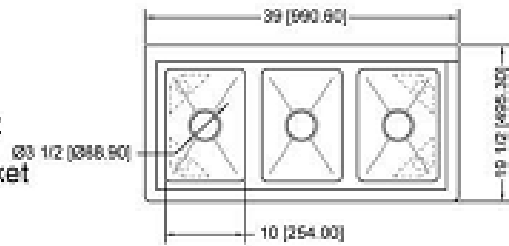

600S31014



Ceiling Tile

School Zone® FINE FISSURED™ &
 School Zone® GEORGIAN™
 Square Lay-in
 medium texture



School Zone® Fine Fissured™ panels with Prelude® 15/16" suspension system (Pgs. 279-280)

This panel is a good choice for classrooms with economical, non-directional ceilings and improved acoustics.

KEY SELECTION ATTRIBUTES

- Get total noise control and design flexibility with Total Acoustics™ ceiling panels: NRC + CAC = Total Acoustics performance
- Excellent sound absorption – products can help comply with ANSI S12.60 Classroom Guidelines

- Economical
- Non-directional visual reduces scrap and installation time
- 30-Year Limited System Warranty against visible sag, mold, and mildew

TYPICAL APPLICATIONS

- Schools
- Healthcare – assists in addressing HIPAA and FGI acoustical requirements
- Libraries/band rooms
- Corridors

COLOR



DETAILS (Other Suspension Systems compatible. Refer to listing on page 228.)



1. School Zone Fine Fissured Square Lay-in
2. School Zone Georgian
3. Fine Fissured Square Lay-in with Prelude 15/16" suspension system
4. School Zone Georgian with Prelude 15/16" suspension system

227 TechLine™ 877 276 7876
 armstrongceilings.com/commceilings



2'x2' LED Troffer

Columbia
LIGHTING

LJT22
2' x 2' LED Troffer

LED



createchange



FEATURES

- Full distribution LED troffer
- Direct replacement for fluorescent 2x2
- Long-life, 60,000 hour LEDs at L80 reduce life cycle maintenance costs
- Four LED color choices and 80 CRI
- Many shielding choices
- Two door frame choices
- Metal to metal light leak protection on all four sides of shielding frame
- Fixed output, step dimming (high/low/off), 0-10V dimming, 0-10V dimming-dim to dark drivers available
- Hinged optical system allows easy access to LED modules and electrical from below the ceiling
- All models standard with IC rating
- DesignLights Consortium® (DLC) qualified with many configurations qualifying for DLC Premium; see www.designlights.org
- Five year warranty

PROJECT INFORMATION

Project Name _____

Type _____

Catalog No. _____

Date _____

CONSTRUCTION

Luminaire housing, end caps, and reflectors are die-formed code-gauge cold-rolled steel. Optical system hinges from either side for easy access to LED module and electrical components. Mechanical light trap prevents light leaks.

CEILING COMPATIBILITY

Designed for recessed installation in standard inverted tee grid ceilings (G), recessed installation in hard ceilings (G with FK accessory), surface mount at ceiling plane (SM), or cable mount suspension below ceiling plane (CM). For compatibility with specific ceilings contact your Hubbell Lighting representative.

FINISH

All metal parts processed with a multi-stage phosphate bonding treatment and finished with a high reflectance baked white enamel.

CERTIFICATION

All luminaires are built to UL 1598 and 2108 standards, and bear appropriate CSA labels. Damp location labeling is standard. Emergency equipped fixtures labeled UL924. Adheres to LM79, LM80 and TM21 industry standards. IC rating is standard on all models. DesignLights Consortium® (DLC) and DLC Premium qualified. Please refer to the DLC website for specific product qualifications at www.designlights.org.

SHIELDING

Lens is high transmission pattern #12 acrylic (A12) for light diffusion without compromise to light output. Other shielding may be specified. If desired shielding media is not shown in ordering guide, contact your local Hubbell Lighting representative.

INSTALLATION

An access plate is furnished with each recessed fixture for fast wiring connections without the necessity to open the fixture or wireway.

WARRANTY

Five year warranty. (Terms and Conditions Apply)

ORDERING INFORMATION

EXAMPLE LJT22-35HLG-FSA12-EU

LJT 22 -			U -			
MODEL	COLOR TEMP	CEILING TYPE	SHIELDING	DRIVER	VOLTAGE	OPTIONS
LJT LED Lensed Troffer	30 3000K 35 3500K 40 4000K 50 5000K	G Grid ¹ SM Surface Mount CM Cable Mount ²	A12 Pattern 12 Acrylic Lens A1212S Pattern 12 Acrylic Lens, 0.125" Nominal A12F Pattern 12 Frosted Acrylic Lens A1212SF Pattern 12 Frosted Acrylic Lens, 0.125" Nominal A19 Pattern 19 Acrylic Lens, 0.156" Nominal A19F Pattern 19 Frosted Acrylic Lens 0.156"	E Fixed Output ESD Step Dimming ED 0-10V Dimming ED1 0-10V 1% Dimming EDD 0-10V Dimming, Dim to Dark ⁴ LUTH Hi-lume 1% EcoSystem LED driver with Soft-on, Fade-to-Black dimming technology ⁵ LUTS S-Series EcoSystem LED driver ⁴	U 120V-277V	C388 3-Wire Flex C488 4-Wire Flex CS88 5-Wire Flex TB4 (4) Bulk T-Bar Clips ELL14 Emergency Battery Pack Installed, 1400 Lumens ⁶ GLR Fast Blow Fuse GTD Generator Transfer Device G1 Single Gasketing (Door to Housing) G2 Double Gasketing (G1 and Lens to Door) G3 Triple Gasketing (G2 and Housing to Ceiling) CP Chicago Plenum
SIZE	LUMEN OUTPUT	DOOR				
22 2' x 2'	VW Very Low Watt MW Medium Low Watt LW Low Watt ML Medium Lumen HL High Lumen VL Very High Lumen	FS White Flash Steel FA White Flash Aluminum				
See Product Availability Table below						

¹ For hard ceilings use Flange Kit accessory.
² Order hanger accessories separately.
³ 50 Watt and below
⁴ For compatibility with Dual-LineGear® inverters in lieu of installed battery pack, contact Hubbell Lighting Representative.
⁵ Not available with 2x2 Surface or Cable Mount.
Damp label—standard.
IC rating—standard.
Page 1/3 Rev. 02/15/17

	VW	MW	LW	ML	HL	VL
E	X	X	X	X	X	X
ESD	X	X	X	X	X	X
ED	X	X	X	X	X	X
ED1	X	X	X	X	X	X
EDD	X	X	X	X	X	X
LUTH	X	X	X	X	X	X
LUTS	X	X	X	X	X	X

ACCESSORIES (ORDER SEPARATELY)
FK22 2' x 2' Single Flange Kit
CN48Y25C3F-NIT 48" Cable Mount Kit for 2' wide CM ceiling type, 3 Wire Feed Cord

LED / LJT22

© 2017 Columbia Lighting, a division of Hubbell Lighting, Inc. Specifications subject to change without notice.
701 Millennium Blvd, Greenville, SC 29607 / Tel 864.678.1000 / Website www.columbialighting.com



LED Commercial Globe String

[Home](#) > [String Lights](#) > [Globe String Lights](#) > [LED Commercial Globe String Lights, 56 Ft Brown Wire, 1.5 in Bulb, Warm White](#)

LED Commercial Globe String Lights, 56 Ft Brown Wire, 1.5 in Bulb, Warm White



SKU: SV-CGBR56-G40LED5WW

Availability: **Out of stock**

Price: \$319.45

Product is out of stock.

Sign up for Email notification

once this product becomes available:

Our 56.3 foot LED commercial grade globe string lights add brilliance to venues and gardens with their warm white LED bulbs. These energy efficient string lights are popular as permanent lighting solutions in restaurants and wedding venue decor. The long lasting design of this strand is ideal in outdoor landscapes with its weather and UV resistant exterior. This strand is end-to-end connectable up to 25 strands, meaning it is the ideal choice for lighting large spaces. Use as patio lights to create starry night scenes in your botanical garden or city park with these durable string lights, or keep the strand year round for wedding venue decor. Complete your design with our [commercial grade string light collection](#).

- Bulb Type: **Warm White LED G40, E17 1.5" Glass Globe Bulb, 0.4 Watts(Included and Replaceable)**
- Light Count: 45
- Total Length: 56 feet, 4 inches
- Lighted Length: 55 feet
- Bulb Spacing: 15 inch
- Lead Length: 8 inch
- Tail Length: 8 inch
- Wire Color: Brown
- Plug Type: Standard
- End-to-End connectable: Yes, 25 additional strands
- Grade: Indoor / Outdoor Commercial Use
- Socket & Fixture: Sockets fit snugly creating a weatherproof seal
- Power (Strand): 130 Volt, 0.15 Amps, 18 Watts
- Idea: Create starry night illumination in your art gallery with this strand draping from the ceiling

Water Fountain

ELKAY. SPECIFICATIONS

GENERAL

Self-contained, wall hung electric refrigerated water cooler. Chilling capacity of 50°F drinking water, based upon 80°F inlet water and 90°F ambient.

Model EZSTL8C has self-closing Easy-Touch Controls on front, left and right of each unit.

Model EZTL8C has self-closing Easy-Touch Controls on the front of each unit.

Model EZSTLDDC non-refrigerated. Same as EZSTL8C without cooling system. (Requires outlet for power cord.)

All models have a hooded stream projector with Easy-Touch Controls that require less than 3 pounds of force to activate commercial-grade solenoid based flow control. Valve with built-in flow regulator provide constant stream from 20 to 105 psi water pressure. Bubbler orifice fully protected to meet all sanitary codes.

NOTE: Minimum 40 psi supply line pressure required in special circumstances where both sides of bi-level are in use simultaneously to ensure adequate stream height. Does not apply to non-refrigerated units.

This model cooler consists of a refrigerated lower unit which requires a water supply, drain outlet and electrical supply.

ADA COMPLIANT

These Water Coolers comply with the requirements of A.D.A. (Americans with Disabilities Act) when properly installed. Unit is compliant if installed in an alcove and is also compliant when mounted on an exposed wall if a wing wall is located on the left side or if LKAPREZL apron is installed under upper unit. Also meets the guidelines for children's environments providing the floor to orifice height is 30" or less on the lower unit and proper clear floor space is provided for parallel approach. (Based on Architectural and Transportation Barriers Compliance Board final ruling.) Check Local and State Codes.

NO LEAD DESIGN

These Water Coolers are certified to be lead-free as defined by the Safe Drinking Water Act. Elkay Water Coolers are manufactured with a waterway system utilizing copper components and completely lead-free materials. These waterways have no lead because all lead materials, such as leaded brass, have been removed. All joints are brazed using silver solder only. No lead solder is permitted. A strainer with an easily cleanable screen is provided to allow trapping and convenient removal of waterborne particulate of 140 microns and larger prior to their entry into the water cooler.

CAPACITIES CHART

Model Number	Base Rate	**GPH of 50°F Drinking Water			Rated Watts	Full Load Amps	Glass Filler Option	Shp. Wt. Lbs.
		Room Temperature °F						
		70°F	80°F	90°F				
EZSTL8C	8.0	9.7	8.8	8.0	370	4.0	Yes	89
EZTL8C	8.0	9.7	8.8	8.0	370	4.0	Yes	89
EZTLDDC	-	-	-	-	-	-	Yes	66
EZSTLDDC	-	-	-	-	-	-	Yes	66

**Based on 80°F inlet water temperature. †Glass filler available at extra cost. Requires factory preparation to receive glass filler. Upper unit only.

Rated watts shown are based on operational (run) time, in compliance with A.R.I. Standard 1010 conditions. Specific applications will determine the actual watts consumed per hour. Watts consumed will be based on number of people served per hour (usage), ambient temperatures, and inlet water temperature.

COOLING SYSTEM

Motor Compressor: Hermetically sealed, reciprocating type, 115VAC, 60Hz single phase. Sealed-in lifetime oil supply. Equipped with electric cord and three prong molded rubber plug (domestic models).

In keeping with our policy of continuing product improvement, Elkay reserves the right to change product specifications without notice. Please visit elkayusa.com for most current version of Elkay product specification sheets.

Elkay
elkayusa.com

2222 Camden Court
Oak Brook, IL 60523

Printed in U.S.A.
©2011 Elkay
(Rev. 4/11) 12-24H

Two Station Wall Mount Water Coolers Barrier-Free Access (Adult and Child) NSF/ANSI 61 Compliant - Models EZTL8C, EZSTL8C, EZTLDDC and EZSTLDDC

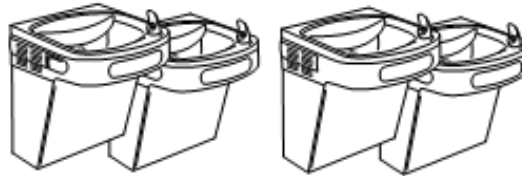

Model EZSTL8C

Model EZTL8C

RATED FOR INDOOR APPLICATIONS ONLY

Condenser: Fan cooled, copper tube with aluminum fins. Fan motor is permanently lubricated.

Cooling Unit: Combination tube-tank type. Tube portion is continuous coil of copper tubing. Tank is stainless steel. Fully insulated with EPS foam which meets Underwriters Laboratories Inc. requirements for self-extinguishing material.

Refrigerant Control: Refrigerant HFC-134a is controlled by accurately calibrated capillary tube for positively trouble-free operation.

Temperature Control: Enclosed adjustable thermostat is factory preset. Requires no adjustment other than for altitude requirements. Easily accessible.

CONSTRUCTION

Frame: Galvanized structural steel chassis supports refrigeration system and fastens to wall. Provides increased structural integrity and rigidity to cooler.

Stainless Steel Basin: One piece polished to a uniform Elkay bright luster finish. Basin has integral drain grid, embossed bubbler pad. No exposed fasteners.

Exclusive Flexi-Guard® Safety Bubbler*: Innovative design utilizes an infused anti-microbial pliable polyester elastomer to prevent accidental mouth injuries. Flexes on impact, then returns to original position. Strong. Abrasion-resistant. Anti-sweat. Keyed in location to prevent rotation.

Upper Shroud: Contoured shock-absorbing, provides additional protection against accidental injury. No exposed fasteners.

Lower Shroud: One piece easy to remove and replace. Allows access to internal components from three sides.

Cabinet: Cabinet design allows for flush to wall mounting. No recess space is required.

Color Selection: Unless otherwise specified cabinet is two-tone gray upper shroud with textured gray lower shroud. Stainless Steel lower shrouds available at extra cost.

Protected by Elkay's 5 Year Limited Warranty on the refrigeration system of the unit.

Elkay Pressure-Type Water Coolers are designed to operate on 20 psi to 105 psi supply line pressure. If inlet pressure is above 105 psi, a pressure regulator must be installed in the supply line. Any damage caused by reason of connecting this product to supply line pressures lower than 20 psi or higher than 105 psi is not covered by the warranty.

STANDARDS

 Elkay Electric Air Cooled Water Coolers are listed by Underwriters Laboratories Inc. and comply with both Canadian and U.S. requirements.

These units comply with A.R.I. Standard 1010.

This cooler is certified by WQA to lead-free compliance including NSF/ANSI 61-ANNEX G, AB 1953.

This specification describes an Elkay product with design, quality and functional benefits to the user. When making a comparison of other producers' offerings, be certain these features are not overlooked.

Two Station Wall Mount Water Coolers
Barrier-Free Access (Adult and Child)
NSF/ANSI 61 Compliant – Models EZTL8C,
EZSTL8C, EZTLDDC and EZSTLDDC

ELKAY
ROUGH-IN DIMENSIONS

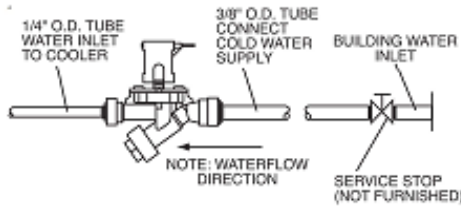

IMPORTANT!
INSTALLER PLEASE NOTE:

This water cooler has been designed and built to provide water to the user which has not been altered by materials in the cooler waterways.
 The grounding of electrical equipment such as telephone, computers, etc., to water lines is a common procedure. This grounding may be in the building but may also occur away from the building. This grounding can cause electrical feedback into a water cooler creating an electrolysis which creates a metallic taste or causes an increase in the metal content of the water. This condition is avoidable by installing the cooler using the proper materials as shown below.

NOTICE

This water cooler must be connected to the water supply using a dielectric coupling. The cooler is furnished with a non-metallic strainer which meets this requirement. The drain trap which is provided by the installer should also be plastic to completely isolate the cooler from the building plumbing system.

OPERATION OF QUICK CONNECT FITTINGS



PUSHING TUBE IN BEFORE PULLING IT OUT HELPS TO RELEASE TUBE

RATED FOR INDOOR APPLICATIONS ONLY

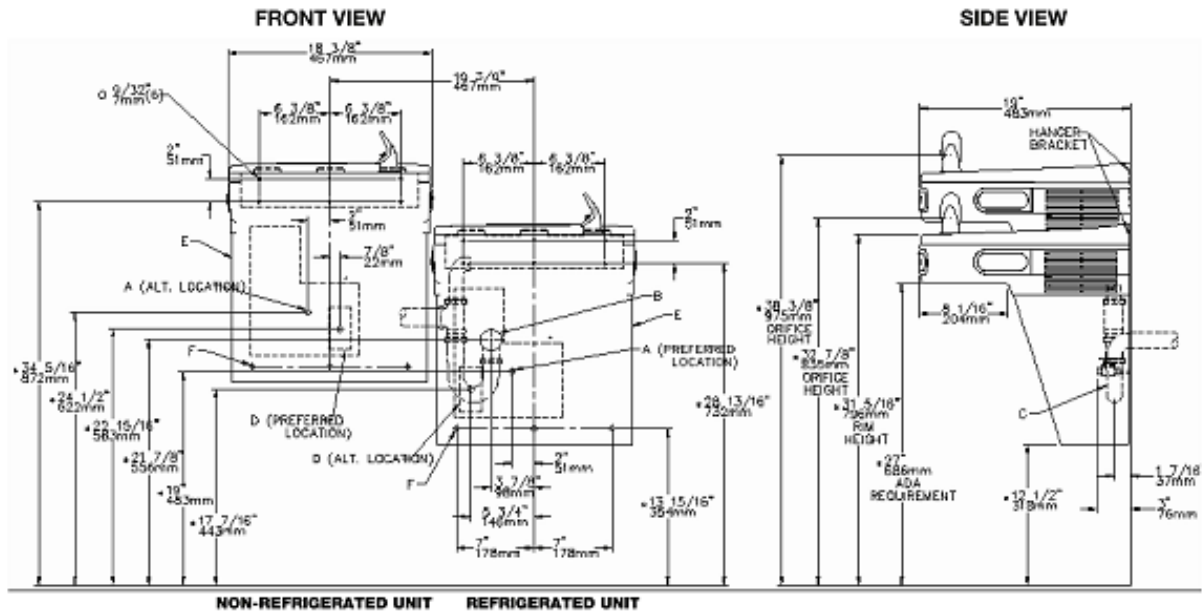

LEGEND

- A = RECOMMENDED WATER SUPPLY LOCATION. SHUT-OFF VALVE (NOT FURNISHED) TO ACCEPT 3/8 O.D. UNPLATED COPPER TUBE. 3" (76mm) MAXIMUM OUT FROM WALL.
- B = RECOMMENDED LOCATION FOR WASTE OUTLET TO ACCOMMODATE 1-1/2" NOMINAL DRAIN. DRAIN STUB 2 IN. OUT FROM WALL
- C = 1-1/2 TRAP NOT FURNISHED
- D = ELECTRICAL SUPPLY (3) WIRE RECESSED BOX DUPLEX OUTLET
- F = 7/16 BOLT HOLES FOR FASTENING UNIT TO WALL

INSURE PROPER VENTILATION BY MAINTAINING 6" (152mm) MINIMUM CLEARANCE FROM CABINET LOUVERS TO WALL.

Elkay

2222 Camden Court
 Oak Brook, IL 60523

Printed in U.S.A.
 ©2011 Elkay

12-24H (Rev. 4/11)

elkayusa.com